

Hydrants and water supplies for firefighting

New policy number: **317**
 Old instruction number: **TEC:F005:a1**
 Issue date: **25 January 2001**
 Reviewed as current: **15 October 2019**
 Owner: **Assistant Director, Technical and Commercial (P)**
 Responsible work team: **Contracts Management Group**

Contents

Part 1 - Overview..... 3

1 Introduction 3

2 Hydrant types..... 3

3 Water supplies from fire hydrants..... 5

4 Hydrants in London..... 6

5 Hydrant installations 7

6 The LFB hydrant inspection process..... 7

7 Devices fitted to hydrants..... 8

8 Unauthorised use of hydrants 8

9 Open water supplies (a.k.a – Emergency water sources)..... 9

10 Hydrants on mobile data terminals (MDT's) 9

11 Hydrant location books 9

12 General enquiries..... 10

Part 2 - Undertaking hydrant inspections and reporting defects 10

1 Station diary 10

2 Hydrant inspections 11

3 Inaccessible or unusable hydrants 13

Part 3 - The safe system of work	14
1 General	14
2 Preparation of work area	14
3 Handling the hydrant cover	14
4 Cleaning out the hydrant pit	15
5 Use of hydrant bar and key	15
Appendix 1 - Key point summary - Hydrants and water supplies for firefighting	17
Document history	19

Part 1 - Overview

1 Introduction

- 1.1 In order to fulfil its responsibilities under the Fire and Rescue Services Act 2004, the LFB undertakes inspections and in-house maintenance of hydrants in agreement with the water undertakers who own the majority of London's (statutory) hydrants. To achieve this, all fire stations undertake inspections of fire hydrants on their ground. Major defects that cannot be remedied in-house are referred to the water undertaker for resolution.

2 Hydrant types

- 2.1 The principal types of hydrant found in the London area are sluice valve and screw-down, with new through bore design hydrants gradually being introduced.

Sluice valve hydrant

- 2.2 This type of hydrant is a legacy design that is no longer installed but still prevalent in Greater London. This hydrant usually runs off a short branch from the water main, the water flowing horizontally past the valve. It consists of three main castings. The inlet piece, which is connected to the pipe, the sluice valve itself and the duck foot bend leading to the outlet. The opening and closing of the waterway is affected by means of a gate or wedge having gunmetal faces. This sits on corresponding faces in the body of the valve. Rotation of the spindle raises the wedge until it is clear of the waterway. The spindle passes through the valve cover by means of a gland and stuffing box. A sluice valve hydrant may be fitted with either a single or double outlet.
- 2.3 This hydrant is usually opened by turning the spindle in a clockwise direction. It should be noted that sluice valve hydrants are usually replaced by the screw down type when major defects on them are reported.

Figure 1 Cross-section of a sluice valve hydrant

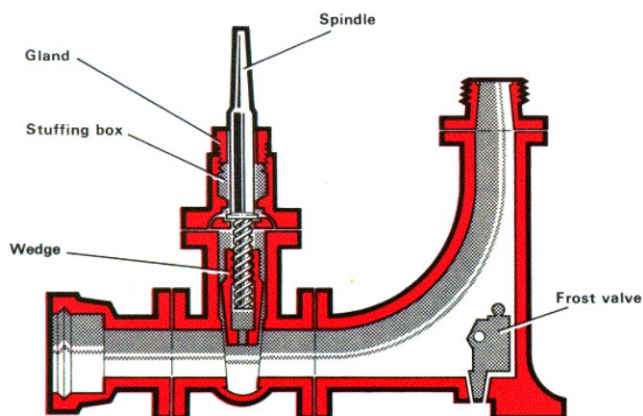

Screw-down hydrant

- 2.4 This type of hydrant may be attached directly to the main or a short branch running off it, which is provided at the chosen point with a vertical extension pipe having a flange to which that of the hydrant is bolted. All screw down hydrants are fitted with a single outlet. A mushroom type valve closes on a seating in the base of the hydrant body above the inlet flange. The valve has a rubber washer, while the seating is of gunmetal. The valve is attached to the lower end of a screwed stem, and is lifted from its seating by the rotation of a hollow spindle into which the stem screws

until it is clear of the waterway. A cover to the hydrant body carries the stuffing box and gland through which the spindle passes. These hydrants are opened by turning the spindle in an anti-clockwise direction.

Figure 2 Cross-section of a screw down hydrant

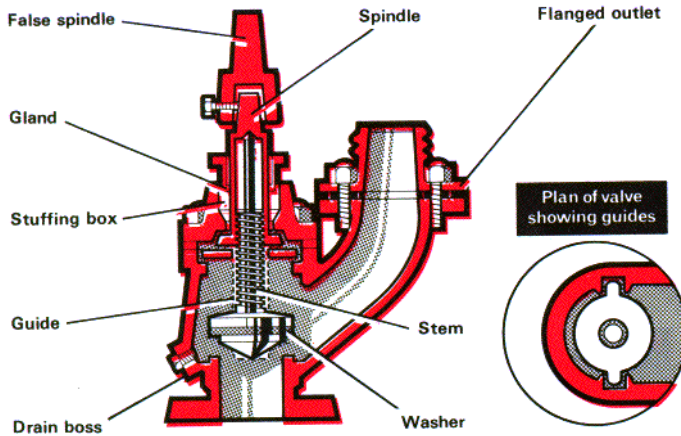

Through-bore hydrant

2.5 Through bore hydrants operate in the same manner described for sluice valve and screw down hydrants, but have a different internal construction for the valve and operating mechanism. This allows water from the water main or supply pipe to flow directly through the hydrant unimpeded and with minimal frictional loss. Although more expensive to manufacture than screw-down hydrants, this design typically provides an improve water flow of about 10%-15% over screw down hydrants under the same conditions.

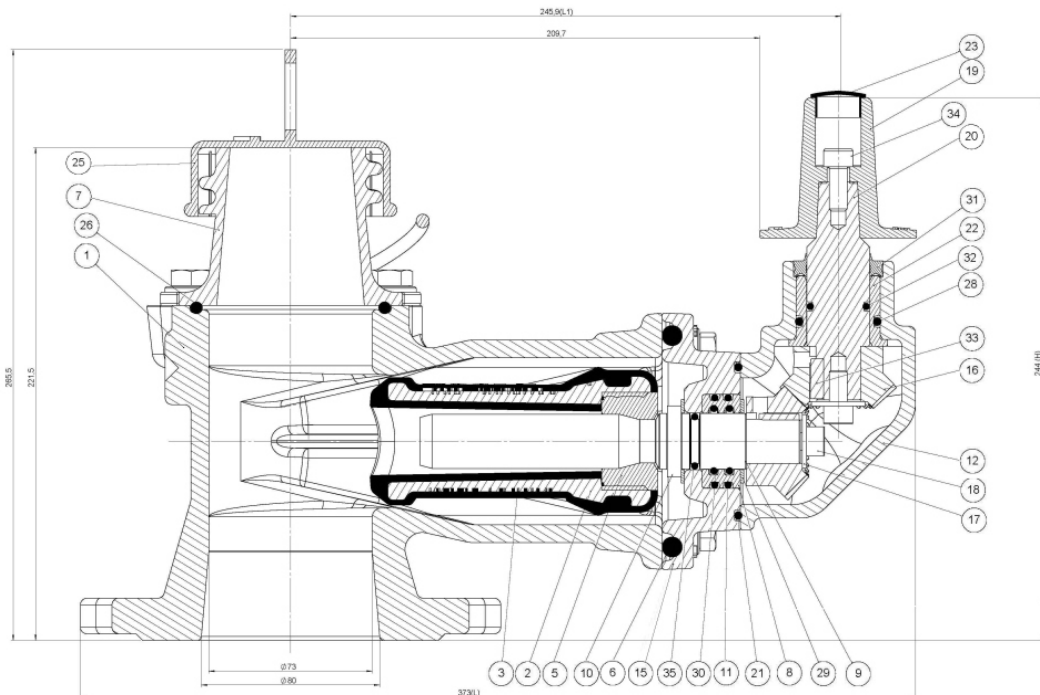

Associated fittings

Frost valves

- 2.6 Where the valve of a hydrant is closed after use, a certain amount of water is trapped in the body of the hydrant between the valve and the outlet. In cold weather, this may freeze and prevent the valve opening. In extreme circumstances it may crack the hydrant body. To prevent this happening, water is drained away from the hydrant by way of either a hole drilled into a gunmetal plug (screw down hydrant) or an automatic valve called the frost valve (sluice valve hydrant).

False spindles

- 2.7 The spindle of a hydrant is usually made of stainless steel, bronze or gunmetal. To protect it from wear caused by the loose fitting hydrant key, a cap known as a false spindle made from a harder metal is fitted over it and secured by a bolt or screwed stud. The false spindle is not designed to be an integral part of the hydrant and may become detached or stolen. All appliances must carry an appropriate number of spare false spindles to ensure an hydrants encountered with their false spindles missing can still be operated for fire fighting or testing purposes.

Outlets

- 2.8 Due to incidences of theft of gunmetal outlets that were fitted to hydrants up until the 1990's, the British Standard for hydrants was revised to address this. Plastic outlets were installed for a time before being superseded by a base metal outlet of limited value. However, older hydrants with gunmetal outlets may still remain in situ and the outlet subject to theft. It has not been possible to combat this to date without introducing measures that impact on operational fire fighting. When a hydrant with a missing outlet is encountered, it should be reported to the Water Team who will arrange replacement. If it is found that a number of hydrants within a local area have had the outlets removed and that there is a severe shortage of working hydrants to provide fire cover as a result, please notify the Water Team via water@london-fire.gov.uk so as urgent action may be taken.

NB – Due to health and safety concerns about plastic outlets which have failed in a small number of cases, a decision has been made that plastic outlets will be replaced for metal ones. These repairs are carried out as and when hydrants with plastic outlets are identified either via the scheduled inspection round or by operational usage. In the event of an emergency, any hydrants with plastic outlets must be used with extreme caution and anyone operating the hydrant must not stand directly above or lean over the standpipe when the hydrant is open and in use. Any hydrants with plastic outlets must reported to the Water Team for a suitable repair at the earliest opportunity.

3 Water supplies from fire hydrants

General water supply requirements

- 3.1 The supply of water in the water undertaker's network is governed by the Water Industry Act and any requirements placed upon them by industry regulator Ofwat. LFB does not have authority to influence this requirement through normal engagement channels and crews should therefore appreciate the statutory obligations in place before reporting low water pressure concerns.
- 3.2 A water undertaker is required by law 'to supply water at a pressure which will reach the top most storey of a residential property including within a block of flats but not at a height greater than it will flow by gravitation through its water mains from a service reservoir'. Ofwat's Guaranteed Standards Scheme requires that the water company must maintain a minimum pressure in the communication pipe of seven metres static head (0.7 bar). The Water Industry Act does not

specify flow and pressure rates for fire hydrants. The National guidance document on the provision of water for firefighting, which does outline suggested flow rates to cover various types of development, is a guidance document, not legislation. The Fire and Rescue Service therefore cannot insist the local water undertaker delivers the flow rates described in this document.

- 3.3 In areas of known low water flow and pressure, Station Commanders should consider an increased Pre Determined Attendance (PDA).

Drought planning

- 3.4 Where London and surrounding areas experiences a sustained lack of rainfall, a water undertaker may implement drought planning measures in accordance with their action plans. These will usually consist of:

- Level 1 - publicity targeted at raising awareness and encouraging reduced usage.
- Level 2 - domestic restrictions, i.e. hosepipe bans.
- Level 3 - business use restrictions.

Should a drought situation continue and the steps above be regarded as insufficient to maintain water supplies, a water undertaker may apply to the Secretary of State for an Emergency Drought Order. Should this be implemented, emergency measures will be introduced to ensure that domestic water supplies are maintained or supplemented by other means.

- 3.5 Water undertakers are required to advise LFB if any of the steps described above are implemented. LFB will issue advice and instructions as appropriate under the circumstances to ensure that measures are taken for water conservation, hydrant testing and operational supplies.

4 Hydrants in London

- 4.1 There are three categories of hydrant found within the London area:

- Statutory.
- City.
- Private.

- 4.2 **Statutory hydrants** - Although there is only one Fire Authority for London, there are four statutory water undertakers whose districts of operation are wholly or partly within this area. Due to recent changes in water industry legislation, there is the opportunity for this number to increase as water undertakers no longer have a monopoly on the geographic areas they once served. In London some 102,000 hydrants have been connected to a water undertakers' mains specifically for fire fighting purposes. These hydrants are known as statutory fire hydrants.

- 4.3 **City hydrants** - Within the City of London, hydrants have been installed and are maintained by the City Corporation. These hydrants are available to the Brigade for fire fighting purposes in the same way as statutory fire hydrants and are inspected by LFB because of the high risks contained in the area. Old pattern city hydrants have two outlets controlled by one valve, which usually opens clockwise. When a city hydrant is renewed by the City Corporation, a modern pattern double sluice valve hydrant with two outlets controlled by separate valves, or single screw down hydrant is installed.

- 4.4 **Private fire hydrants** - Water undertakers' mains are usually in public thoroughfares. Consequently, buildings occupying extensive sites (e.g. hospitals, railway goods yards, generating stations and some blocks of flats) may be some distance from the nearest main. In these cases (usually in accordance with recommendations made by the LFB Water Team) the owners of the property may provide, at their own expense, private hydrants on an independent

supply pipe connected to the nearest main, or other adequate water supply. Their maintenance is the responsibility of the owner concerned.

- 4.5 **Fire Station yard hydrant defects** - It should be noted that defective hydrants located in fire station yards must not be reported to the Water Team. PFI stations (Dagenham, Dockhead, Leytonstone, Mitcham, Old Kent Road, Orpington, Plaistow, Purley and Shadwell) must report station yard hydrant defects to the Blu 3/Kier Helpdesk via 01256-366833. All other Fire Stations must report such defects to the Kellogg Brown & Root (KBR) Intelligent Contact Centre (ICC) on extension 89100 option 2

5 Hydrant installations

- 5.1 New hydrants in residential areas are normally spaced at a distance of 180 metres, although historically they have been installed at lesser distances. The only exception to this will be cul-de-sac or dead end locations where it is normally not necessary to install hydrants if the distance to the nearest hydrant in the adjacent road is 90 metres or less.
- 5.2 In areas of high risk where shorter distances may be preferable, hydrants will normally be spaced at a distance of no less than 90 metres. High-risk areas may be identified by such premises as manufacturing or warehouse complexes, bulk oil/petrol storage, large timber distribution areas or houses of multiple occupation, although these examples are by no means exhaustive.
- 5.3 The decision on where hydrants are to be located within new developments will normally be made by the LFB's Water Team using the GIS database available for this purpose. Please note that the Fire and Rescue Service is not a statutory consultee on water for firefighting provisions so is not always consulted.
- 5.4 Wherever possible, hydrants are installed in footways immediately adjoining carriageways or surfaces that will take the load of a pumping appliance. The top of the outlet should be more than 100mm (but not more than 300mm) below surface level. Any hydrant that does not meet this standard should be reported to the Water Team.

6 The LFB hydrant inspection process

- 6.1 The purpose of undertaking hydrant inspections is to identify the overall condition of the hydrant and allow station personnel to remain familiar with the location of hydrants in the context of their station ground. The activity arises from the statutory obligation to secure water supplies for fire fighting contained in the Fire Services Act and provides an assurance that hydrants installed for this purpose have not fallen into a state of disrepair through either lack of use, wear and tear or damage/vandalism, i.e. that all reasonable steps are taken to ensure that hydrants produce a supply of water for operational fire fighting and operate safely in doing so, including their infrastructure.
- 6.2 LFB currently operates a rolling four yearly hydrant inspection process. This means that approximately one quarter of the hydrants within each station ground are inspected by fire crews in year one, a further quarter in year two and so on. The inspection period runs from 1st March and its length (the active months in which inspections can be undertaken and outcome data handled) is determined by the appropriate principal manager (currently the Director of Operations). The start of each year's inspection round and active months will be circulated in advance.
- 6.3 The station-based process is planned and undertaken via Station Diary. Each station watch is responsible for creating appointments in Station Diary to ensure that hydrants due for inspection are inspected in their due months. Information on hydrants due for inspection in the active

months and the numbers completed are available from the link to the hydrant inspection pages once an appointment is created. Management information on the overall hydrant inspection process is also available from a report via this [link](#)).

- 6.4 All hydrants that are reported by stations as defective are firstly visited by one of the LFB's Water Team Hydrant Technicians. Hydrant Technicians carry a range of tools in a service van that allows a number of minor repairs to be carried out in house. This is both timely and cost effective. The inspection cycle allows defective hydrants to be visited by the Hydrant Technicians shortly after the station inspections are completed. The priority for the Water Team Hydrant Technicians is to attempt to remedy hydrants that are reported as either inoperable for firefighting purposes or in a potentially hazardous condition. Since hydrant locations are available on MDT's within the appliance, replacing missing hydrant marker plates is a lesser priority that is undertaken as a single activity later in the year.
- 6.5 Where defects cannot be remedied in house (i.e. because they require the water supply to be shut down, the hydrant to be dismantled or similar more extensive work) these defects are passed to the appropriate water undertaker as repair orders to be completed in an agreed timeframe. It is important to note that during winter months London experiences higher incidences of burst water mains because of the aging water main infrastructure in a predominantly clay soil. During this time, the water undertaker's priority is to respond to burst mains to ensure that water supplies can be restored as quickly as possible. For this reason, LFB's hydrant inspection programme aims to have orders placed before the winter season to avoid hydrant repairs remaining outstanding for longer than desired.
- 6.6 Comprehensive information on undertaking the physical inspection of fire hydrants is addressed in part 2 of this policy.

7 Devices fitted to hydrants

- 7.1 From time to time, devices may be found that have been fitted to a hydrant by the local water undertaker. Pressure monitors are generally attached to the hydrant outlet and used to monitor the water supply network. Caps may also be fitted to hydrant outlets to address leakage problems. Occasionally a very small number of hydrants, in agreement with the London Fire Brigade Water Team, may be fitted with locking devices where there have been reported and repeated issues of illegal hydrant usage. These locking devices are removed within an agreed period of time, normally around 3 months. More information on the range of devices fitted to hydrants can be found on hotwire via the following [link](#)
- 7.2 If a fire hydrant fitted with a device is required for operational use, the device should be removed carefully in line with the information provided on hotwire. **NB - As a precaution, the operator should not stand directly above the device whilst removing it.**

If a hydrant is encountered with a device fitted to it during routine hydrant inspections, the hydrant should not be inspected and the device left in situ. The inspection outcome for the hydrant should be entered as 'Defective-Inoperable' and the defect code is 'Outlet Defective – Capped'. Such returns should also be annotated as 'Unable to inspect – logging device fitted'. A hydrant technician will visit the hydrant at a later stage.

8 Unauthorised use of hydrants

- 8.1 Misuse of a fire hydrant means use other than for firefighting under the Fire Service Act or as authorised by the undertakers or owners of the hydrant. Any such misuse may render the person concerned liable to a fine. Additionally, any person who damages or obstructs a fire hydrant, unless using it for an authorised purpose is also, on conviction, liable to a fine.

8.2 In London, most water undertakers authorise the use of fire hydrants without reference to the Brigade and such authority may be in respect of one hydrant for a specified period, or may be a general authority, e.g. to a Borough Council. Any case of unauthorised use brought to the notice of a local officer is to be reported immediately to the Water Team by telephone or e-mail (address water@london-fire.gov.uk) giving the following information/evidence:

- The location of the hydrant.
- The date on which the hydrant was observed in use.
- The name, address, telephone number and vehicle registration number of the individual or company using the hydrant, if known.
- Any photos of the hydrant in illegal use, should you have them.

9 Open water supplies (Emergency water sources)

9.1 Where appropriate and available, crews may use an open water supply to supplement firefighting using water from an adjacent fire hydrant. Their use and method of extraction will be determined by the officer in charge at the incident. Open water supplies include rivers, lakes, ponds, swimming pools or similar. These are subject to inspection from time to time to ensure that they are still available for use.





9.2 Where Fire Stations identify new and suitable open water supplies, they should notify the Water Team as soon as possible so these sources can be added to the LFB hydrant and open water source database. This information will then be published on the MDT's carried on fire appliances.

10 Hydrants on mobile data terminals (MDT's)

10.1 Hydrants are displayed on all MDT's in appliance cabs. Information is updated on a weekly basis and drawn from the LFB's hydrant database. Hydrants that are displayed as defective usually derive their status data from the latest hydrant inspection and will remain as such until the defect is either remedied by a Hydrant Technician or the water undertaker. The Water Team take all steps to ensure data displayed on MDT's is accurate and up to date, however sometimes mistakes do occur and the Water Team is reliant on information relayed from users on the fire ground or during inspections. If any data displayed on MDT's is found to be incorrect, staff should inform the Water Team as soon as possible so the information can be investigated and corrected where necessary.

10.2 Open water supplies are also displayed on MDT's by an icon that shows the point at which an appliance can park adjacent to the supply in order to extract water from it. Open water supplies are inspected from time to time to check that their availability has not altered.

10.3 The icons for hydrants and open water supplies displayed on MDT's are shown below.

-  Operable fire hydrant.
-  An operable fire hydrant that has a minor defect.
-  An inoperable fire hydrant that will not supply water for firefighting.
-  Open water supply.

11 Hydrant location books

11.1 Hydrant location books are available to supplement the information provided by mobile data terminals. They are printed by stations locally and stored in a standard A4 ring binder which is carried on station appliances. A hydrant location book can be produced via this [link](#) (it can be formatted as required).

12 General enquiries

- 12.1 Reports of hydrant defects are to be investigated and resolved as far as possible at station level before being reported to the Water Team if any further action is required. General enquiries or complaints regarding fire hydrants from members of the public or other bodies that cannot be answered at station level are to be emailed or referred to the Water Team (water@london-fire.gov.uk).

Part 2 - Undertaking hydrant inspections and reporting defects

This section explains the steps required to create a time slot on Station Diary, the generation and completion of hydrant inspection sheets and the physical inspection of fire hydrants.

1 Station diary

Creating time slots on Station Diary

- Open Station Diary.
- Create new appointment for hydrant inspections.
- From category list, select station activity.
- From subject, select 'Hydrant/EWS inspections'.
- A button marked 'Hydrant System' appears on the appointment front page (see image to side).
- Select the date and time slot for the activity.
- Select OK.

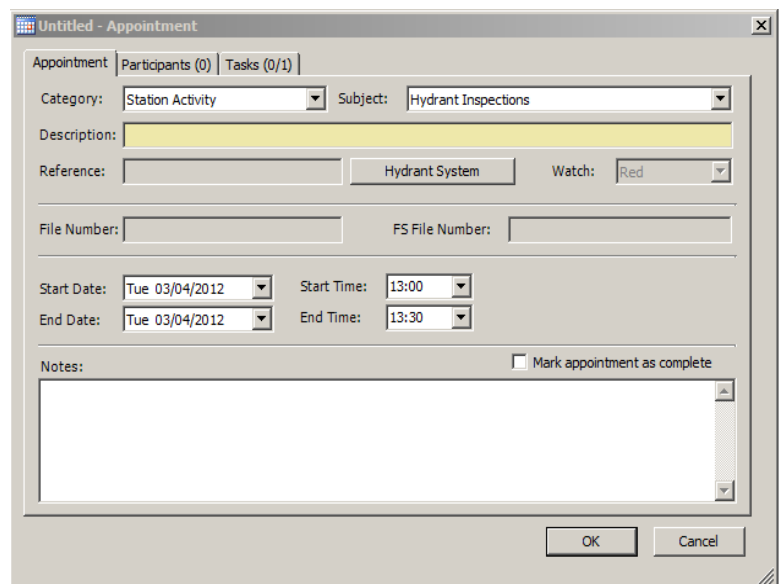

Accessing and printing hydrant inspection sheets

- 1.1 To access the page displaying the hydrants due to be inspected by a watch for the month, click the 'Hydrant System' button in the appointment.
- This launches the Water Management Module.
 - The hydrants to be inspected by your watch this month will be displayed.
 - Select the print icon.
 - A map should also be printed to assist crews carrying out the inspections in locating the hydrants using the map tab. It should be configured to landscape.

Carrying out physical inspections

- 1.2 The new hydrant inspection sheets show columns to indicate
- The hydrant number.
 - The address of the hydrant.
 - The inspection result (satisfactory or unsatisfactory).
 - The fault codes for an unsatisfactory hydrant.

- Notes which can be added as free text for where it is helpful to provide some additional information.
- 1.3 The printed inspection sheets should be completed with the inspection findings as the physical inspections are undertaken. On return to the station, the information recorded is then entered electronically as explained below.

Entering hydrant inspection findings through Station Diary

- Open Station Diary.
- Select the appointment for the hydrant inspections that have just been undertaken.
- Select the hydrant button to access the hydrant inspection sheets.
- Click on the icon adjacent to the hydrant number.
- You now see a screen for you to input information with the hydrant's address at the top.
- Use the additional information box below the hydrant's address to enter any additional location information (i.e. by side entrance).
- Using drop down box, select the inspection outcome. Note that if faulty – non operable is selected, this means the hydrant is not available for operational use.
- If OK is selected as the inspection outcome, then press 'Update' to complete.
- If the inspection outcome is not OK, this has to be supported by one or more fault codes.
- Click on a fault code in the 'Faults Code' box and use the right arrow key to transfer it to the 'Hydrant Faults' box. Repeat if required for an additional fault code.
- If an incorrect fault code has been selected, highlight it in the 'Hydrant Faults' box and select the left arrow to remove.
- If additional notes are required, enter them in the 'Notes' box.
- Once satisfied that all the information is correct, press 'Update'.
- Once the 'Update' button is selected, the hydrant inspection is complete.
- This information is now sent to the Water Team for action and is no longer visible at the station.
- Close the Water Management Module, this will return you to the Station Diary.
- The inspection appointment can now be marked as 'Complete' in the normal way once the participants and time frame have been updated.

Note -as the information for each hydrant in that month is entered, this will update the overall hydrant inspection figures at the top of the page.

2 Hydrant inspections

- 2.1 Personnel carrying out hydrant inspections are to wear work-wear uniform with cap and if appropriate, a fire tunic. Fire boots are to be worn instead of shoes. The driver of the appliance may wear shoes while engaged in driving.

NB - When hydrants are tested or inspected, all efforts must be made by crews to remedy any defect(s) found where it is possible to do so.

- 2.2 Each hydrant is to be tested in the following manner using a standpipe and operating key and bar.
- **Outlet to be tested.** Conduct a check of the outlet to ensure it is in good order and is attached firmly to the hydrant. A standpipe should then be fitted to the outlet to ensure that the thread or connection is in good order. ***NB – If the hydrant has a plastic outlet or the outlet is damaged, please do not attempt to ship a standpipe and operate the hydrant. Any hydrant with a plastic outlet should not be used during testing as there have been a few instances of the plastic outlets failing and nearly causing serious injury. Any hydrants with plastic outlets***

must be reported as a matter of urgency to the Water Team as defective either via the hydrant inspection round process or via an e-mail to water@london-fire.gov.uk

- **Hydrant charged.** With a standpipe, head and blank cap connected to the outlet, the valve should be partially opened to release a small quantity of water through the hydrant. The flow of water must be directed to the gutter, using a length of hose if necessary.
- **Valves to be tested.** With the standpipe still in position a blank cap should be inserted in the head (or the valve in the standpipe head should be closed), and the hydrant opened to its fullest extent. Whilst under this pressure, all joints should be examined for signs of leakage. The hydrant should then be turned off and, if the cap is not fitted with an air release, the standpipe should be unshipped without the blank cap being removed (or the valve in the standpipe head being opened).
- **Frost valve.** The frost valve (where fitted) should be checked to see that it operates in a satisfactory working order.

Note: These tests should not be carried out in cold weather where there is a likelihood of water freezing as this could present a slip hazard to the public.

2.3 A hydrant should only be considered defective and reported as unsatisfactory if it:

- Cannot be used for operational purposes; and/or
- Has a defect which does not render the hydrant unusable, however, it cannot be resolved by the fire crews and needs attention from a LFB Water Team Hydrant Technician; and/or
- Presents a significant hazard to the general public.

2.4 In addition to the standard testing procedure described above, the following points should be noted:

Frost valve: Failure of the frost valve may sometimes be remedied by tapping lightly on the elbow flange with the blunt end of a hydrant bar. If a frost plug is fitted to a screw down hydrant and fails to drain the bend, the drilled hole can often be cleared by inserting a thin, sharp object such as a piece of wire or similar. If there are signs of the main valve letting by, the hydrant is to be flushed out to remove any foreign matter that may be preventing the valve from seating properly. NB: A defective frost valve is not a notifiable defect.

Frame and/or cover: Where a damaged frame and/or cover constitutes a serious hazard to the public, the Water Team should be informed immediately by phone or e-mail (water@london-fire.gov.uk).

Spindle Leaks: These are rarely of a reportable nature when the hydrant is in the closed position and should not be reported as defects unless the spindle leak results in water collecting in the hydrant pit above the level of the outlet when the hydrant is closed, or they present a hazard to the public because the water is not contained in the hydrant pit and is over spilling into public areas. This includes the occupiers of neighbouring premises who may suffer damage from the leakage, particularly where there is a dwelling, a basement or a cellar below street level. Spindle leaks will generally cease once the packing gland becomes wet. Slow leaks where the water does not collect in the pit above the level of the outlet should not be reported as defective unless they pose a risk to the operator or members of the public when the hydrant is in operation.

Tight spindles: These can usually be eased using the full extent of a hydrant bar. However, under no circumstances should excess force be used as this could result in injury as well as further damage to the hydrant. If the hydrant cannot be opened after easing the spindle, this should be reported as defective.

False spindles: These are to be checked to ensure that they are securely fixed to the true spindles. However, missing false spindles should not be replaced or reported as a defect as false spindles are carried on all Fire Appliances .

Hydrant pit: A pit defect should only be reported if the hydrant is unusable or presents a hazard to the public.

This is to be inspected for loose brickwork or cement packing. Some pits are rendered watertight because of vaults etc. underneath. Broken or cracked cement rendering should therefore also be noted and the possibility of leakage considered. Any debris or silt is to be removed from the hydrant pit using the salvage scoop and bucket carried on the appliance. The collected debris or silt should be disposed of carefully and in accordance with the appropriate policies.

NB - Very occasionally crews may find used hypodermic needles in the hydrant pit. Please do not attempt to remove these needles when testing the hydrant. Please report the defect to the Water Team via the inspection results process. The Water Team will arrange to have the pit cleaned.

If a hydrant is needed for an operational incident and contains used hypodermic needles in the pit, it will be for the Incident Commander to decide if it is safe to use the hydrant.

Hydrant tablet: This is to be cleaned and any small deficiencies, such as missing screws, remedied if possible (it should be noted that hydrant tablets can also be secured to wall, posts etc. with binding tags or other means – however, hydrant marker tablets must not be attached to trees or any other vegetation under any circumstances). The numbers indicating the distance to the hydrant cover are to be checked and reported to the Water Team if not correct.

Hydrant marker posts: Where a concrete tablet and post is found to be damaged, every effort should be made to make it safe for the public. Only in extreme cases should the fire crew attempt to remove the reinforced concrete marker post and crews should note that the concrete marker posts often have a concrete base under the pavement which helps to keep the marker post stable and secure. No trip hazards must be left as a result of any works carried out by crews. The Water Team is to be contacted immediately, enabling the necessary arrangements to be made with the water undertakers to have the post removed safely and/or ensure the area is made good.

Bolts, joints and lugs: The hydrant is also to be inspected for slackness of any bolts or joints. Lugs of old pattern valve body covers are to be examined for signs of breakage.

3 Inaccessible or unusable hydrants

Obstruction of hydrants

- 3.1 If it is found that a hydrant cannot be used, examined or tested because of obstruction, road or footway improvements, or other work in progress, the Sub Officer/Station Officer is to take such remedial action as is possible and inform the Water Team using the hydrant inspection resulting process, an e-mail to water@london-fire.gov.uk , or via the telephone Monday to Friday, 7am to 5pm.

Excavation work adjacent to hydrants

- 3.2 If it is noticed that excavation work for the erection of buildings or for the laying of pipes, etc. is in progress adjacent to or below any hydrant pit or hydrant branch pipe, the Sub Officer/Station Officer is to take such action as is possible to ensure that the hydrant is not rendered inoperative and inform the Water Team. The work is to be inspected to see that the hydrant is properly secured and accessible for Brigade purposes and that any damage or disturbance to the hydrant pit and the frame cover is made good.

Part 3 - The safe system of work

1 General

- 1.1 This section describes the steps to be followed in gaining access to a hydrant and operating it for testing purposes in a safe manner.
- 1.2 Hydrant tests should be undertaken by not less than two fire station personnel. One person must be nominated to maintain an awareness of passing pedestrians, vehicles and other traffic so that work can be carried out safely for the operator and without risk to the general public.
- 1.3 There are 4 main steps to be followed when undertaking minor repairs. They are:
 - Preparation of work area.
 - Handling the hydrant cover.
 - Cleaning out the hydrant pit.
 - Use of the hydrant bar and key.
- 1.4 The safe system of work to be followed for each step is described below.

2 Preparation of work area

- 2.1 The operative should make sure that the area surrounding a hydrant is set up in a safe manner before work begins. This requires assessing any risks that may affect operatives, pedestrians, vehicles or other passing traffic.
- 2.2 In pedestrian areas, any potential risks to pedestrians are to be taken into account and they should be directed away from the working area. When working at the roadside, the appliance is to be parked adjacent to the hydrant with warning lights on and in a manner that shields the operatives from oncoming traffic. In exceptional circumstances where the location of the hydrant means that the level of risk from passing traffic is unreasonably high, the Water Team is to be informed.

3 Handling the hydrant cover

- 3.1 Hydrant covers have evolved in design over many decades. Whilst generally square or rectangular, they can differ in size and depth and may be grey/black or painted yellow. They generally weigh from 15kg to 75kg although new composite material designs are being manufactured that are significantly lighter. They can be lifted using the hydrant bar in one of two ways. For covers containing a lipped, cut-away section at one or either end of the cover, the flat end of the hydrant bar should be inserted under the lip in order to gain leverage. Covers containing a circular, cut-away section allow the hydrant bar to be inserted to a further degree in order to gain leverage.

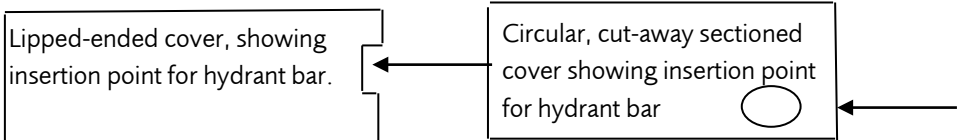

Comprehensive information on the variety of hydrant designs that can be found in London can be found on hotwire via this [link](#).

- 3.2 Once leverage using the bar has lifted the cover, the remaining removal action should be carried out with the cover remaining in contact with the ground. This will ensure that the majority of the weight remains on the ground and is not borne by the operative. Where a heavier style of cover is being lifted, assistance from a second operative will allow the first operative to raise the cover using the bar. The second operative can then safely move the cover away from the hydrant pit using both hands. The cover should remain in contact with the ground at all times so that the ground rather than the operative supports the majority of its weight. The second operative should wear fire-fighting gloves during this stage. All operations should be performed whilst maintaining good posture; that is, keeping the back straight to prevent unnecessary strain. Newer style hydrant covers are compact but sit more deeply in their accompanying frame. These covers are designed to be lifted directly upwards from the frame they sit in. They may appear to 'stick' during lifting if a hydrant bar is inserted at one end and removal attempted in the same way as thinner style covers. Users should find the correct method of lifting to be a simple process upon familiarity with the type of cover.
- 3.3 Once the cover has been lifted from the pit, it should be placed away from the working area before work begins, having due regard to the advice contained in 16.1 above.

4 Cleaning out the hydrant pit

- 4.1 The hydrant pit is to be cleaned by removing excess water and any objects, including soil or debris, that may affect the operation of the hydrant. Fire-fighting gloves are to be worn during this procedure to guard against dirty water and the potential presence of sharp objects. The operative should endeavour to maintain a good posture. Excess water is to be removed from the pit using a scoop or similar device before removing any debris. Extreme caution should be taken to avoid contact with any sharp objects that may have entered the pit. NB - Very occasionally crews may find used hypodermic needles in the hydrant pit. Please do not attempt to remove these needles when testing the hydrant. Please report the defect to the Water Team via the inspection results process. The Water Team will arrange to have the pit cleaned. A supply of plastic bags used to cover sandbags should be carried on the appliance during the course of hydrant testing. These are to be used to store pit debris. The bags should be disposed of upon return to the station.

5 Use of hydrant bar and key

- 5.1 The hydrant is operated by firstly fitting a false spindle of the correct size over the spindle of the hydrant. The bolt on the false spindle should be tightened so that it is properly secured over the hydrant spindle. Once the standpipe has been fitted to the outlet, the key is placed securely onto the false spindle and the bar located in the head of the key. The key is then turned in the direction indicated on the reverse of the hydrant cover, which is usually anti-clockwise. This allows the main valve to open and water to flow.
- 5.2 Care must be taken to avoid using excessive force when turning the bar and key. The operation should be performed slowly, since opening the valve too quickly may cause pressure changes within the mains that can either result in damage to the water main which could significantly affect the supply of water for firefighting, or displace particles which normally rest at the bottom of the water main. This can cause discolouration or contamination of the drinking water supply. In some cases the spindle may be situated close to the outlet, resulting in contact between the hydrant key and standpipe. Care is to be exercised when turning the bar and key to avoid the operative's hand striking the standpipe. Good posture is to be maintained whilst this operation is performed as demonstrated in the photographs below. (**Note:** that these are to illustrate good posture only and not current work wear/PPE).

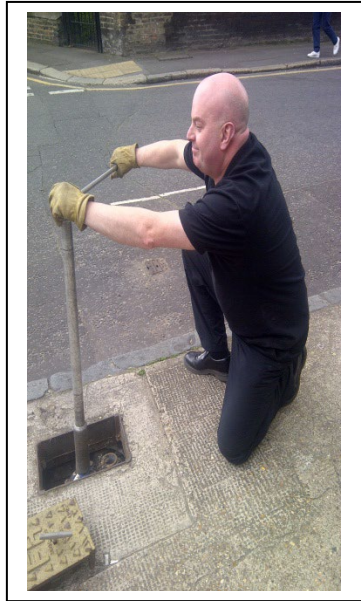

Appendix 1 - Key point summary - Hydrants and water supplies for firefighting

This policy provides information on the types of hydrants that are found in London, the arrangements for undertaking tests and inspections and the reporting of defects to the Water Team.

Hydrant inspections are carried out in LFB on a four year rolling programme. Where appropriate, water may also be drawn from an open water supply.

Types

There are two main types of hydrants found in the London area:

- Sluice valve.
- Screw-down.

A new type of hydrant, a through-bore design, is being introduced offering a reduced frictional loss but very few of these have been installed to date.

Three categories of fire hydrant, statutory, city and private.

Installations

- Since year 2000, hydrants in residential areas have been spaced at a distance of 180 metres.
- Exceptions can be made but, in areas of higher risk, fire hydrants will normally be spaced at a distance of no less than 90 metres.
- In London, hydrants are normally installed in footways immediately adjoining carriageways or surfaces that will take the load of a pumping appliance.

Operating a hydrant

- Old sluice valve hydrants open clockwise, newer hydrants usually open anti-clockwise.
- Hydrants must always be operated slowly and carefully in accordance with the safe systems of work.
- When a standpipe is attached and the hydrant is in use, under no circumstances should anyone lean over or stand directly above the standpipe. This is to reduce the risk of injury should the outlet fail for any reason.
- Hydrants must be closed down slowly and fully after use.
- If a hydrant is found to have a plastic outlet or has hypodermic needles in the pit, it is recommended that an alternative hydrant is used and the defects are reported to the Water Team so as an appropriate repair can be made. If the hydrant is required for urgent operational use the decision as to if it can be used safely will be made by the Incident Commander.
- After using and closing down the hydrant, care must be taken to ensure the hydrant cover is refitted properly in the frame and that no trip hazards are present.

Hydrant water pressure and flow rate

- Relevant standards do not specify any minimum requirement for flow rates from a hydrant.
- Ofwat's Guaranteed Standards Scheme requires that the water company must maintain a minimum pressure in the communication pipe of seven metres static head (0.7 bar). The reality is companies usually deliver a minimum of 1.5 bar.
- Crews should consider this before reporting hydrants as suffering low flow or pressure rates and it may be advisable to arrange additional pumping appliances via the Pre-determined Attendance Team for areas of high risk.

- During an incident, hydrant flow and pressure can often be temporarily increased through liaison with the water company either by using a water company turncock operator or by remote operation from the water company headquarters to increase the flow of water in the network. Assistance on water supply issues at incidents is to be arranged via Brigade Control.
- LFB staff **must not under any circumstances** attempt to turn stopcocks or control valves in order to increase water pressure themselves as this may cause serious damage to the water network resulting in heavy leakage and expensive repairs. In the worst case scenario, it may be that no water is available from the hydrant if the pipes serving the hydrant burst or are significantly damaged.
- In drought conditions the water companies are required to notify the brigade of any impacts on water supply and any emergency plans.

Inspections and tests

- LFB's inspection cycle tests all statutory fire hydrants on a rolling programme over a four year period.
- The inspection period begins in March each year and concludes in October. This cycle may vary if agreed by principal managers.
- City hydrants are also inspected and tested but their maintenance falls to the City of London.
- Private hydrants are not currently inspected as they are the responsibility of the hydrant owner.
- When carrying out inspections and testing, station personnel must:
 - Test the hydrant outlet (NB – during the inspection and testing round any hydrants with a plastic outlet should not have a standpipe shipped due to Health and Safety concerns. Instead they must be reported to the Water Team for a suitable repair).
 - Charge the hydrant.
 - Test the valves.
 - Check the frost valve.
 - Attempt to resolve any minor defects with the hydrant wherever possible.

Station personal should be mindful of water run off and aim to discharge water from a hydrant undergoing testing into the gutter or another suitable place. Hydrants should not be tested in very cold weather when water may freeze causing a trip hazard to the public.

Reporting defects

- All stations will carry out hydrant inspections using the procedures described in this policy.
- If a defective hydrant needs attention outside of the normal inspection cycle or because of extraordinary circumstances, please e-mail the Water Team mailbox (water@london-fire.gov.uk) giving the hydrant number, location, nature of defect and the reason why it is urgent. Alternatively you can contact the Water Team via the telephone, Monday to Friday 7am to 5pm.

Devices fitted to hydrants

- Devices are used by water companies to monitor the pressurised water network (the mains) or to address leakage.
- They are fitted to the outlet of a hydrant, and there are various types in use although designs can vary. Devices can be removed from hydrants required for operational use by following the information in this policy and the information available on hotwire.
- NB – hydrants with a logger fitted are usually left in the fully open position and must be shut down slowly before attempts are made to remove the logger.

Document history

Assessments

An equality, sustainability or health, safety and welfare impact assessment and/or a risk assessment was last completed on:

EIA	21/05/13	SDIA	H - 21/05/13	HSWIA	22/08/18	RA	
-----	----------	------	--------------	-------	----------	----	--

Audit trail

Listed below is a brief audit trail, detailing amendments made to this policy/procedure.

Page/para nos.	Brief description of change	Date
Page 3	Key Point Summary Added	10/02/2010
Pages 7-11, Section 9	Replaced in its entirety, Please read through to familiarise yourself with the new content	10/02/2010
Throughout	Update of Hydrant maintenance and inspection	10/02/2010
Pages 14-15, 16.1, 16.3	Updated with new information	10/02/2010
Throughout	This policy has been reviewed as current with major changes, please read through the complete document to familiarise yourself the changes. PN364 has been cancelled as the content has been incorporated into this policy.	21/05/2013
Page 18	SIA date has been added to this policy.	22/01/2014
Page 17	Key point summary removed from page 2 and new appendix 1 – key point summary flowchart added.	19/08/2014
Page 18	Subject list and FOIA exemptions tables updated.	16/12/2014
Throughout	Reviewed as current with minor updates throughout. Please re-read to familiarise yourself with the changes.	15/06/2016
Page 1	Updated contact from Head of Operational Resilience to Procurement and Technical & Service Support	23/01/2017
Throughout	Reviewed as current with minor updates and role to rank changes throughout. Please re-read to familiarise yourself with the changes.	15/10/2019

Subject list

You can find this policy under the following subjects.

Assets	Water hydrants and supplies
Water	Hydrants
Firefighting	Mobile data terminals (MDTs)
Responding to an incident	

Freedom of Information Act exemptions

This policy/procedure has been securely marked due to:

Considered by: (responsible work team)	FOIA exemption	Security marking classification